

1 2 3 4 5 6

A

B

C

D

A

B

C

D

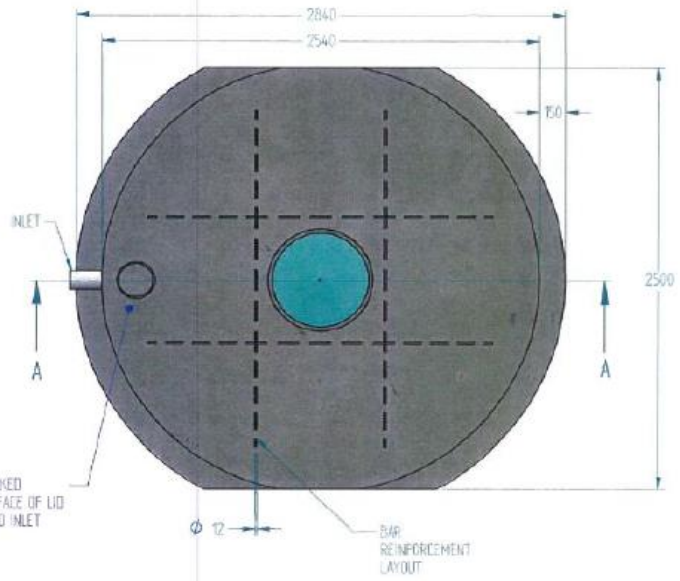

TANK TO BE MARKED "INLET" ON TOP FACE OF LID AND ADJACENT TO INLET

BAR REINFORCEMENT LAYOUT

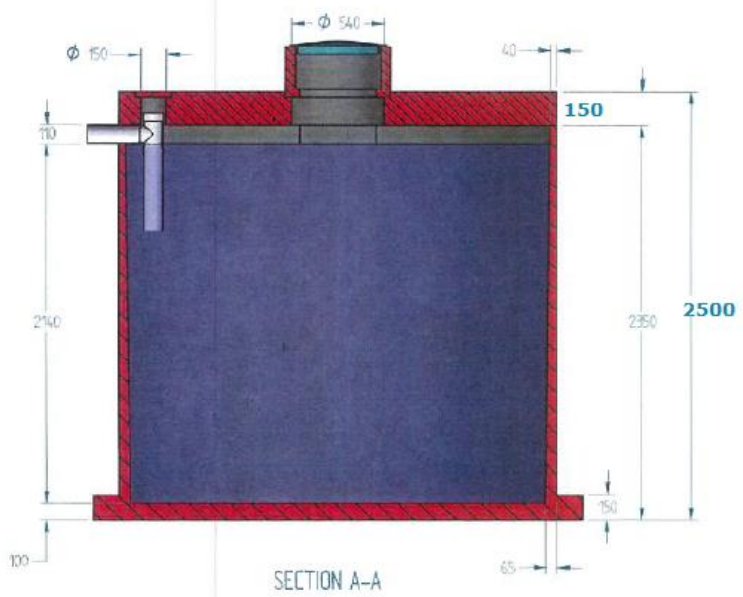

SECTION A-A

TANK ALSO TO BE MARKED ON TOP FACE OF LID AND ADJACENT TO INLET WITH:
 "ECONOCYCLE"
 DATE OF MANUFACTURE
 "CAPACITY = 9930L"
 "THE LID IS NOT TO BE LOADED OR COVERED IN ANY WAY OTHER THAN FOR INSPECTION"
 "COMBINED TANK AND LID WEIGHT = 6000kg"

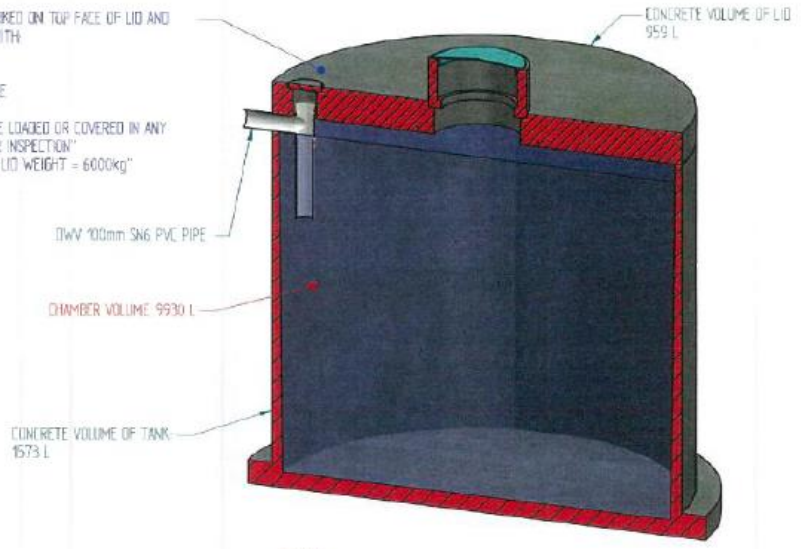

100mm S46 PVC PIPE

CHAMBER VOLUME: 9930 L

CONCRETE VOLUME OF TANK: 1573 L

CONCRETE VOLUME OF LID: 959 L

APPROVED
 - 3 JUL 2018
 NSW MINISTRY OF HEALTH

NOTES:

GENERAL

1. SEPTIC TANKS MANUFACTURED AND TESTED IN ACCORDANCE WITH AS/NZS 1546.1:2008

MARKING

TANK TO BE MARKED AS NOTED ON THIS DRAWING

CONCRETE:

1. CONCRETE STRENGTH f_{ck} = 40MPa
2. SLUMP = 100mm
3. MAXIMUM AGGREGATE SIZE = 10mm
4. CONCRETE TO BE VIBRATED TO ENSURE THOROUGH COMPACTION
5. TANKS TO BE REINFORCED WITH FIBRE STEEL OF 600MPa MINIMUM TENSILE STRENGTH - OR EQUIVALENT, MIXED TO ACHIEVE A MINIMUM OF 75kg/m³ OF CONCRETE
6. LID TO BE REINFORCED WITH TWO LAYERS OF S172 STEEL MESH 30mm ABOVE THE BOTTOM
7. LARGE LID INSPECTION HOLE TO BE REINFORCED WITH R12 DEFORMED BAR AS SHOWN
8. ALL STEEL REINFORCEMENT TO AS/NZS 4671

ATTACHMENTS:

1. LIFTING HOOKS TO BE 'REID SWIFT LIFTS 4 x 25' (TONNEL) ANCHORS TO BE CAST INTO THE BASE OF THE TANK
2. 3 x 13 TONNE ANCHORS TO BE CAST INTO THE TANK LIDS

HYDROSTATIC UPLIFT:

1. ANCHORAGE SHALL BE PROVIDED ON TANKS THAT ARE INSTALLED OTHER THAN ABOVE GROUND AND WHEN THEY ARE NOT PERMANENTLY FILLED TO THE FULL HEIGHT SHOWN ON THIS DRAWING.

<p>ABATED WASTEWATER TREATMENT SYSTEMS</p>		PROJECT	
		10,000L COLLECTION WELL CERTIFICATION DRAWING	
COPYRIGHT NO DRAWING OR PRODUCT LOGOING WITHOUT THE WRITTEN PERMISSION OF ECONOCYCLE OR ANY OF ITS SUBSIDIARIES OR ASSOCIATES WWW.ECONOCYCLE.COM	<p>UNLESS OTHERWISE SPECIFIED ALL DIMENSIONS ARE IN MM</p>	DATE PUBLISHED	29/06/2017
		SCALE	DO NOT SCALE
DRAWING LAST MODIFIED BY Peter McKillop		PARTS	2540x2350-10000-CW
MASS 5906 kg		VERSION	---
		SHEET No.	1 OF 1